

# Development of Autopilot Unmanned Smartboat Vehicle(AUSV) Based on Fishing Zone Prediction Map

Afif Zuhri Arfianto<sup>1, a)</sup> Tri Budi Santoso<sup>2)</sup> Tarwiyono Santoso<sup>1)</sup>

Mohammad Basuki Rahmat<sup>1)</sup> Nyoman Gunantara<sup>1)</sup>

<sup>1</sup>*Dept. of Marine Electrical Engineering, Politeknik Perkapalan Negeri Surabaya*

<sup>2</sup>*Dept. of Electrical Engineering, Politeknik Elektronik Negeri Surabaya*

<sup>3</sup>*Dept. of Electrical Engineering, Universitas Udayana*

<sup>a)</sup>Afif Zuhri Arfianto : afif@ppns.ac.id

**Abstract.** The potential of marine fish is one of the hopes for fishermen. Fishing boats have not been equipped with fish detection devices such as fish finders. To get to the location of fishing, fishermen do not know accurately the distance and direction of the ship. Fishermen only rely on experience and information from other fishermen to find out the location of the fish distribution. The ship's fuel losses are caused by fishermen having to go around to map fishing points. Accurate data for autopilot technology is needed to move the fishing boat to the point of distribution of fish, serves to help fishermen to increase fishing yields and reduce ship fuel losses. The 70x16x15 cm ship prototype with autopilot technology measures the distance between fishing boats and the target location of the nearest fish distribution. This prototype is equipped with a GPS and a compass sensor that shows the direction and difference of angles to the direction of the target. This prototype has a rudder that is driven by a servo motor based on the angle difference to the setpoint. Based on the results of research and testing, this prototype can run average distance of 15.5 m. The results of angle accuracy testing, prototype has an angle difference. The compass angle and bearing angle are an average difference of 35.33 °.

**Keyword :** Autopilot Unmanned Smartboat Vehicle, Angle Accuracy, Fishing Zone Prediction Map

## 1. INTRODUCTION

One of the navigation technology on ships is autopilot. The use of ship's autopilot technology to control manoeuvres of rudder angle movements and automatic steering gear settings has not been used as a means of finding fish distribution points for fishers. Based on data obtained from the Central Statistics Agency of East Java Province that capture fisheries in 2013 - 2015 experienced an insignificant increase, in 2013, capture fisheries amounted to 386,895 tons to 416,529 tons in 2015 [1]. Within two years, an increase in the catch of East Java Province was 3.7%. The factors that cause it are fishing activities carried out by fishermen based on experience and information from other fishers, while the distribution point of the fish changes every time. One of the factors causing the distribution of fish to change is oceanographic factors. Oceanographic factors are factors that influence the physiological conditions of the fish that cause the fish to migrate according to their physiological conditions [2].

The technology for finding fish distribution points is a fishfinder. Fishers come to the location of the fish distribution to do the mapping, while each time the distribution of fish changes. The safety of fishers is at stake because the potential of the fish and its distribution point is in the middle waters. Fishers who use the fishfinder must also continue to search for the distribution point of their fish, based on experience or from other fishermen's information. Fishfinder only detects the waters under the ship. Fishers experience loss of time and fuel because they have to do

mapping and searching manually. Today eco friendly technology is an important issue. Not only in applied technology but also material that can absorb micro wave energy [3][4]. Technology for optimization of fishing has been found by Affandi et al. with the concept of VMS (Vessel Messaging System). Also using website-based internet technology and radiofrequency. The service on the interactive website is to know the position of the ship and interactive messages between VMS service users (family, government, shipowner) and fishers at sea [5].

Autopilot is a system control application on moving vehicles such as aeroplanes, helicopters or ships, which serves to stabilize the direction of motion in the desired time and the direction of the programmed path[6][7]. The development of autopilot prototypes is used for testing new control algorithms and the reliability of other electronic components such as sensors and microprocessors [8]. In the field of rocket control, the control system is used to guide the rocket in the desired direction. The rocket's track can be read from the inertia sensor or additional from GPS data. Changes in the motion of the rocket's path by changing the direction of the thrust of the rocket motor, or by rotating a few degrees of the tilt of the rocket's fins by utilizing the principle of aerodynamic forces. To develop this system, the use of a rate-gyroscope to calculating angles and a stable control actuator is an essential part of the system[9].

## 2. LITERATURE REVIEW

### 2.1 Fishing Zone Prediction Map

Fishing Zone Prediction Map (PPDPI) contains information on fishing area prediction and potential areas for pelagic fishing in Indonesian waters. The information on PDPI map is regularly updated 3 times a week, (Monday, Wednesday and Friday). This innovation is one of the tools for fishermen in determining fishing locations in order to optimize the catch quota. The PDPI map also provides information on wind direction and wave height so fishermen can predict weather conditions around fishing locations for sailing safety. Equipped with PDPI map information, fishermen can precisely find out and quickly head to the fishing ground area, thus can increase the effectiveness and efficiency of fishing, especially for fuel saving. The data show the distribution spots in the form of latitude and longitude. The following is a map of fish distribution data from 8 - 10 June 2018 [10].

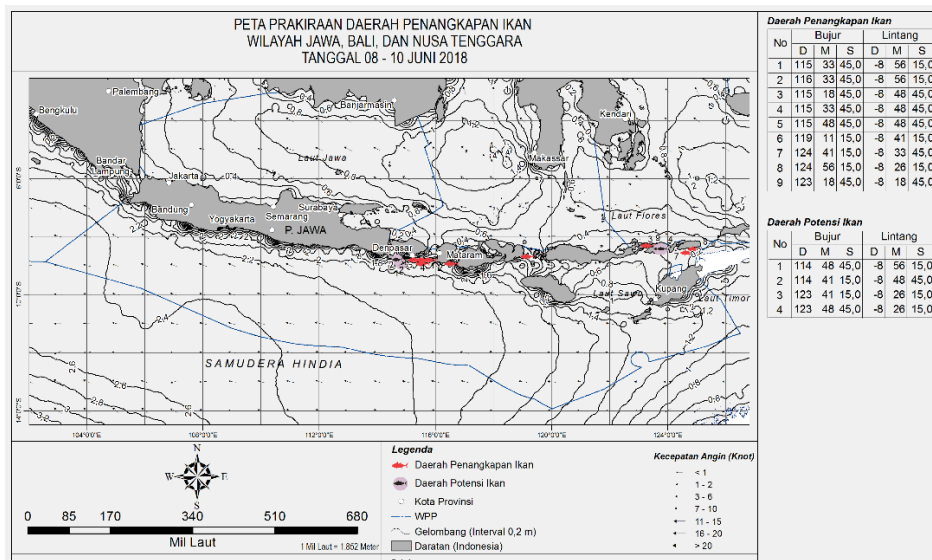

FIGURE 1. Fishing Zone Prediction Map (PPDPI)

As shown in Figure 2.1, the fishing spots are marked with a red fish symbol. Meanwhile, the potential fish area is marked with a black fish symbol. The fishing spots and potential fish area have their own location based on the coordinates

TABLE 1. Map Specification

Type	: Prediction of Fishing Zone
------	------------------------------

<b>Purpose</b>	: Fishery
<b>Keyword</b>	: PPDPI
<b>Area</b>	: Indonesia
<b>Time span</b>	: 2010-01-01 - now
<b>Vertical Span</b>	: -
<b>Temporal Resolution</b>	: Every 3-day (national), everyday (fishing port and specific waters)
<b>Spatial Resolution</b>	: 4 km (national), 1 km (fishing port and specific waters)
<b>Update</b>	everyday
<b>Platform</b>	: Aqua/Tera Satellite, Suomi NPP
<b>Sensor</b>	: MODIS, VIIRS
<b>Format</b>	: raster (.png), database (.dbf)

The map is prepared and intended for fishers with a fleet capacity of > 30 GT with predictive areas up to the high seas or Indonesia's Exclusive Economic Zone (EEZ). The National PDPI Map is compiled and published routinely three times a week (Monday, Wednesday and Friday) and covers five territorial of Indonesia, namely: Sumatra, Kalimantan, Sulawesi, Maluku-Papua, Java Bali-Nusa Tenggara. The map was prepared and intended for traditional fishers (one-day fishing) who operate not too far from the coastal area, especially fishers who use ships <30 GT. Map of PDPI Fisheries Port is compiled and published routinely every day and covers 11 territorial of Indonesia, namely: PPN Ambon, PPS Belawan, PPS Cilacap, PPN Kejawanan, PPN Pelabuhan Ratu, PPN Pemangkat, PPN Pengambangan and Perairan Bali, PPN Sungailiat, PPP Tamperan Pacitan, PPN Ternate Bitung, PPN Prigi. The map is arranged for specific waters that intersect with conservation areas where there are boundaries of restricted areas for fishing. This Specific Waters map is updated and published every day covering 3 territorial waters: North Bali (Bali Sea), East Bali (Lombok Strait), Savu Sea

## 2.2 Autopilot Angle Calculation

Autopilot angle calculation works with Neo 7M GPS Modul. It capture signals from satellites that are converted at latitude and longitude coordinates. Neo 7M GPS Modul can be used to determine the ship's movement by uniting the coordinates of the destination and the initial coordinates of the ship. Alternatively, in determining the direction of the ship using the tilt angle from the primary angle of the north pole of the earth, so the formula that can be applied is the formula of polar coordinates and cartesian coordinates. Polar coordinates are handy one of them in astronomy. Polar coordinates can be used to prove the trigonometric identity formula, as well as the formula for the sum and difference of trigonometric comparison.

The material that can be taken is the size of angles, degrees, radians, and cycles, comparisons of trigonometry in right triangles, values of trigonometric comparisons in various quadrants, and trigonometric comparisons of related angles. Polar coordinates are coordinates on the cartesian which located on a circle  $x^2 + y^2 = r^2$  so that the polar coordinates are written based on the radius of the circle (r) and the angle formed with the positive X-axis. Suppose the Cartesian coordinates of point A are (x, y), and the polar coordinates of point A are (r,  $\alpha$ ), the relation between the two points is  $x = r \cos \alpha$ , and  $y = r \sin \alpha$ . The steps to change coordinates to cartesian coordinates are as follows using the relationship:  $x = r \cos \alpha$ , and  $y = r \sin \alpha$ . Steps to change cartesian coordinates to polar coordinates:

Determine the radius (r) with the Pythagorean equation 1.

$$r^2 = x^2 + y^2 \quad (1)$$

Determine the angle size with one of the formulas:

$$\sin \alpha = \frac{y}{r} \quad (2)$$

$$\alpha = \sin^{-1} \frac{y}{x} \quad (3)$$

For the quadrant, there are four possibilities:

- x positive and y positive, is in quadrant I,
- x negative and y positive, is in quadrant II,
- x negative and y negative, is in quadrant III,
- x positive and y negative, is in quadrant IV,

### 3. RESEARCH METHODOLOGY

This stage is an activity to create a concept that is run on a prototype tailored to the background of the problems raised and research objectives. The concept of the system consists of identifying problems and designing system concepts in the form of system inputs and outputs. The following system design work in Figure 2.

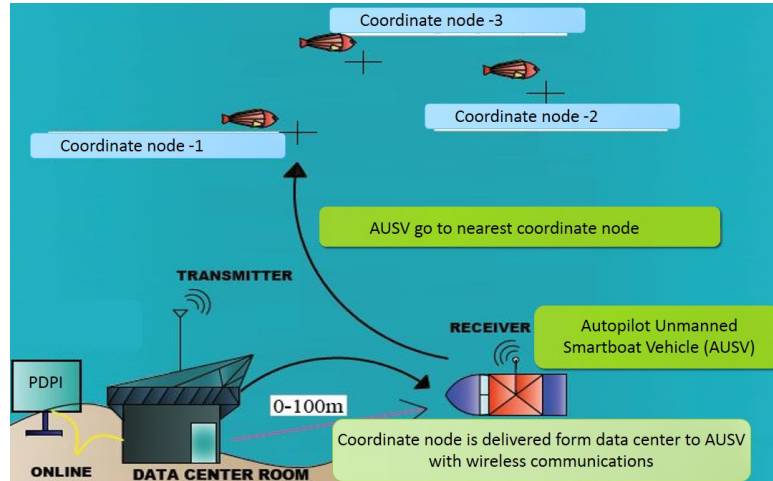

FIGURE 2. Autopilot Unmanned Smarboart Vehicle System.

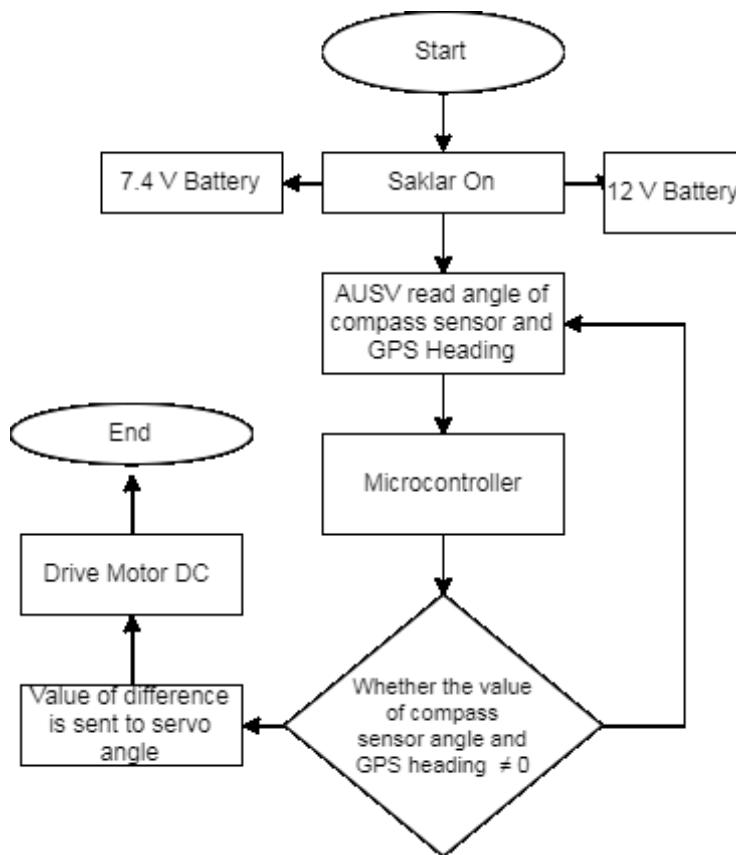
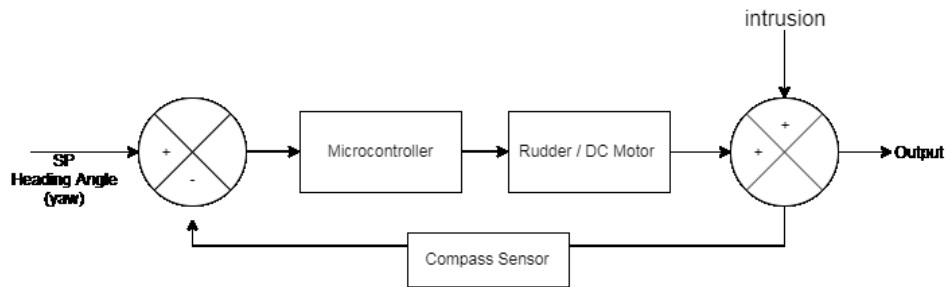

FIGURE 3. Flowchart of AUSV system

The process of research methodology is, first designing the control diagram to the prototype. The function of the control diagram is to know the workflow of the control system on the prototype with the close-loop control process. The following diagram controls the closed-loop control in Fig 4.



**FIGURE 4.** Controll Model

The setting point is the GPS heading angle (yaw), which is the angle between the position of the target and the position of the ship. Arduino input is processed in the form of an error signal obtained from the yaw difference with the compass sensor reading angle. Arduino-processed error signals control the ship through servo motion. Outside disturbances that can occur when the ship's journey to the target point is in the form of wind and water waves that can affect the difference in angle between the yaw and the compass angle. The error signal is compared to the setpoint through the feedback signal of the compass sensor angle reading. The output of the system is the difference between the yaw angle as the setpoint and the compass sensor reading angle must be  $0^\circ$ .

This system works by sending fish distribution point data from the BPOL website to the data centre. The data centre is connected to the internet. Data of fish distribution points are sent to ships using radiofrequency with a distance between 0-100 m. The ship will receive the fish distribution point data sent by the transmitter and detect its location with the help of GPS sensors and compass sensors. The ship will go to the point of location for the distribution of fish on autopilot. The receiver system concept consists of input, process, and output. The input consists of a compass sensor, GPS sensor and destination location data input from the transmitter. Destination location data after received by the receiver and compass sensor and GPS sensor reading data, then processed by the microcontroller. The microcontroller process gives an order to the actuator in the form of a rudder movement control action with PWM servo motor and pm DC motor as the prime mover of the prototype. The buzzer is added as a prototype distance indicator with the destination location. The transmitter system concept consists of input in the form of location data for fish distribution destination inputted via a PC or using a 4x4 matrix keypad. Input data is processed by the microcontroller and gives the command NRf2410 to send data to the receiver. Data sent by NRf24101 is displayed on a 20x4 LCD.

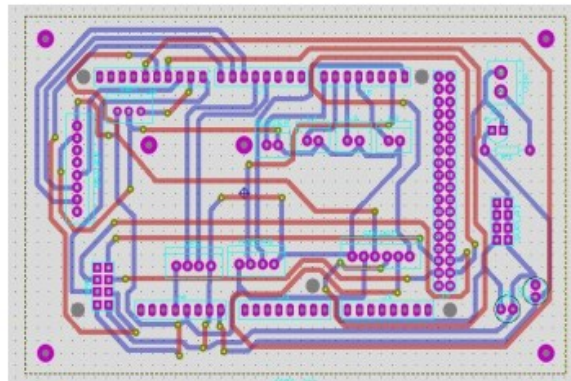

**FIGURE 5.** PCB design for on AUSV board

Wireless communication between microcontroller devices is needed for data communication between fishing stations and prototypes. The NRF24L01 module is a device designed for long-distance communication that utilizes the 2.4 GHz RF band. This module uses the SPI interface to communicate. The working voltage of this module is 3.3 VDC. This module has eight pins including VCC (3.3 VDC), GND, CE, CSN, MOSI, SCK and IRQ. Electric motors are electromagnetic devices that convert electrical energy into mechanical energy. DC motors or often called direct current motors, are often used for purposes that require speed regulation compared to AC machines. The main reason for the use of DC machines, especially in modern industry, is because the working speeds of DC motors are easily regulated. DC motors are well known for their diverse uses by combining various shunt windings that are shunted, series or separately. A motor can be designed that can display the characteristics of volt-amperes or varying moment-speeds -sort for dynamic and fixed state use.

Servo motor is a rotary device or actuator that is designed with a closed-loop feedback control system so that it can be set-up or set to determine and ascertain the angular position of the motor output shaft. Servo motor is a device consisting of a DC motor, gear circuit, control circuit and potentiometer. Gear circuits attached to the DC motor shaft will slow the shaft rotation and increase the torque of the servo motor, while the potentiometer with its resistance changes when the motor rotates serves as a determinant of the position limit of the rotation of the servo motor shaft.

Servo motors are controlled by providing a Pulse Wide Modulation (PWM) signal via a control cable. The pulse width of the control signal provided will determine the rotation angle position of the servo motor shaft. For example, a pulse width of 1.5 ms (milliseconds) will rotate the shaft of the servo motor to an angular position of 90°. If the pulse is shorter than 1.5 ms, it will rotate in the 0° or left position 22 (counterclockwise), whereas if the pulse is given longer than 1.5 ms, the shaft of the servo motor will rotate in the 180° position or right (clockwise). Servo motor rotation is controlled by given a voltage source and control signal. The amount of the voltage source depends on the specifications of the servo motor used. Meanwhile, to control the rotation of the servo motor is done by sending a control pulse with a frequency of 50 Hz with a period of 20ms and different duty cycles. Where to move a servo motor of 90° pulses are required with a 1.5ms ton duty cycle of positive pulses and to move 180° requires a pulse width of 2 ms.

#### 4. RESULT AND DISCUSSION

Prototype angle accuracy testing to ensure the performance of prototype accuracy with bearing angle. Prototype runs according to trajectory and error does not until 90°. The test results data, it be shown in Table 2.

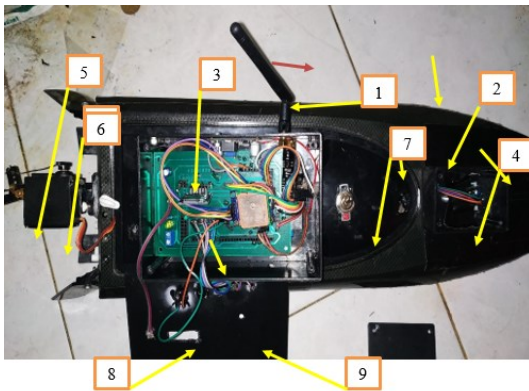

No	Part Name	No	Part Name
1	Antena Nrf24l01	7	Switch
2	Hull	8	Buzzer
3	Box Control	9	Led Indicator
4	Compass Sensor		
5	Rudder		
6	Servo Motor		

FIGURE 6.a. Part of Prototype

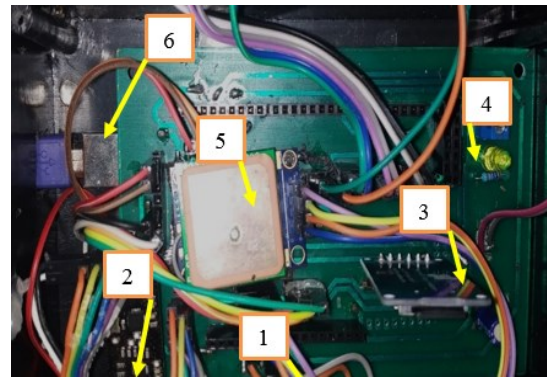

No	Electronic Component Name
1	Buck Converter
2	NRf24l01
3	MicroSD
4	Led Indicator
5	GPS Sensor
6	USB Port

FIGURE 6.b. Electronic Component

**TABLE 2.** Testing data

No	Distance (m)	Compass Angle (°)	Bearing(°)	Error (%)	No	Distance (m)	Compass Angle (°)	Bearing(°)	Error (%)
1	19	349	323.35	25.65	11	8	323	325.39	2.39
2	18	298	323.66	25.66	12	7	325	326.52	1.52
3	16	324	319.91	4.09	13	6	327	330.01	3.01
4	15	332	318.11	13.89	14	5	333	332.12	0.88
5	14	325	316.31	8.69	15	4	339	337.33	1.67
6	13	309	314.93	5.93	16	3	347	343.62	3.38
7	12	312	315.23	3.23	17	1	348	324.19	23.81
8	11	327	315.94	11.06	18	2	345	116.75	228.25
9	10	329	317.15	11.85	19	2	0	116.75	116.75
10	9	326	322.35	3.65	20	2	336	124.73	211.27

The test was carried out twenty times. The results show that the prototype has an angle difference. The compass angle and bearing angle are an average difference of 35.33 °.

## 5. CONCLUSION

Based on the making and testing Autopilot Unmanned Smartboat Vehicle(AUSV) Based on Fishing Zone Prediction Map show that the prototype can run average distance of 15.5 m. The prototype has an angle difference. The compass angle and bearing angle are an average difference of 35.33 °.

## REFERENCES

- [1] BPS, *Statistik Sumber Daya Laut dan Pesisir 2017*, II. Jakarta: Badan Pusat Statistik (BPS), 2017.
- [2] H. Suhartono and J. B. Pailin, "Identifikasi dan Prediksi Daerah Penangkapan Ikan Kembung (*Rastrelliger spp.*) di Perairan Kabupaten Pangkep," *J. Amanisal*, vol. 2, no. 2, pp. 55–65, 2013.
- [3] M. B. Rahmat, A. Z. Arfianto, E. Setijadi, and A. Mauludiyanto, "Test of microwave absorber of rice husk and burned rice husk," in *2017 International Conference on Advanced Mechatronics, Intelligent Manufacture, and Industrial Automation (ICAMIMIA)*, 2017, pp. 331–333.
- [4] M. B. Rahmat *et al.*, "Measurement and Simulation of Microwave Absorber from Burned Rice," in *2018 International Conference on Applied Science and Technology (iCAST)*, 2018, pp. 99–102.
- [5] A. Z. Arfianto and A. Affandi, "Rancang Bangun Layanan Website Interaktif Pada Sistem Komunikasi Vessel Messaging System (VMeS)," *Bachelor Thesis, Surabaya Inst. Technol. Surabaya, Indones.*, 2010.
- [6] W. Widada, P. Pusat, and T. Wahana, "Rancang Bangun Prototipe Sistem Heading Autopilot Berbasis Ra Te-Gyroscope Dan," *LAPAN Jakarta.*, 2006, vol. Vol. 4 No., 2006.
- [7] R. B. Widodo *et al.*, "Grasping and Attached Mode in Human-Computer Interaction in the Study of Mouse Substitution," *J. Phys. Conf. Ser.*, vol. 1196, no. 1, p. 012034, Mar. 2019.
- [8] R. A. Atmoko, D. Yang, M. I. Abas, A. Z. Arfianto, and R. Rahim, "Teleoperation cloud industrial robot using XMPP protocol," *Int. J. Recent Technol. Eng.*, vol. 8, no. 3, pp. 6280–6284, 2019.
- [9] R. Watiasih, . P., and . S., "Rancang Bangun Purwarupa Robot Kapal Pendeteksi Limbah Minyak," *Pros. Semin. Nas. Teknol. Elektro Terap.*, vol. 1, no. 01, pp. 25–30, 2017.
- [10] I. for M. R. and Observation, "Peta Prakiraan Daerah Penangkapan Ikan," 2019. [Online]. Available: <http://bpol.litbang.kkp.go.id>.